

# ITT

Wastewater

## Goulds Pumps

ST31 Submersible Sump/  
Effluent Pump



### FEATURES

---

- Corrosion-resistant construction.
- Cast iron body.
- Thermoplastic impeller and cover.
- Replaceable power cord.
- **Bearings:** Upper sleeve and lower heavy duty ball bearing construction.
- **Built-In Vent Hole:** Prevents air-binding with no added labor.
- Motor is permanently lubricated for extended service life and is powered for continuous operation. All ratings are within the working limits of the motor.
- Complete unit is heavy duty, portable and compact.
- Mechanical Seal: carbon/ceramic/Buna/stainless steel.
- Stainless steel fasteners and stainless steel pipe plug.



Goulds Pumps is a brand of ITT Water Technology, Inc.  
- a subsidiary of ITT Industries, Inc.

[www.goulds.com](http://www.goulds.com)

*Engineered for life*

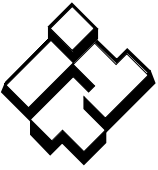

# ITT

## GOULDS PUMPS Wastewater

### APPLICATIONS

Specially designed for the following uses:

- Basement draining
- Water transfer
- Dewatering
- Effluent Transfer

### SPECIFICATIONS

#### Pump:

- Discharge size: 1½" NPT
- Capacities: to 50 GPM.
- Maximum head: to 26 feet.
- Temperature: 104°F (40°C) maximum, continuous when completely submerged.
- Solids handling: ½" maximum sphere.
- Automatic models include a float switch.
- Manual model available.
- Pumping range: see performance chart on back or curve below.

### MOTOR

- ST31: ½ HP, 115 V, 60 Hz, single phase, 3000 RPM, 12.0 amps maximum.
- Built-in thermal overload protection with automatic reset.
- Class B insulation.
- Oil filled design.
- High strength carbon steel shaft.
- Power cord: Quick disconnect 10 foot standard length, heavy duty 16/3 SJTW with NEMA 5-15 P three prong grounding plug, 115V.

### AGENCY LISTINGS



**Tested to UL 778 and  
CSA 22.2 108 Standards**  
By Canadian Standards Association  
File #LR38549

Goolds Pumps is ISO 9001 Registered.

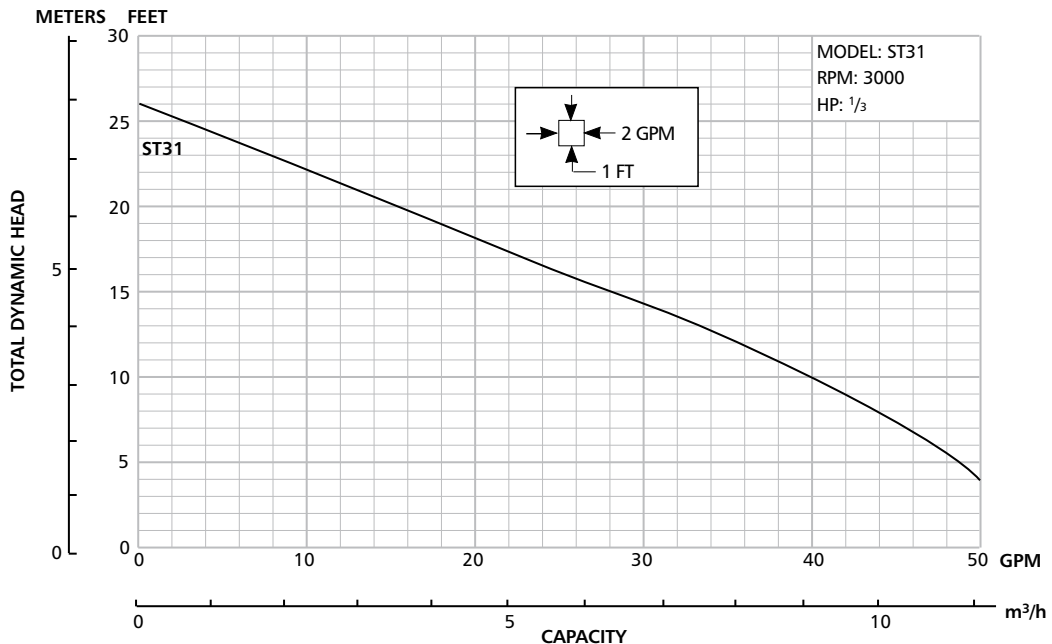

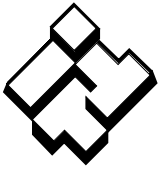

# ITT

## GOULDS PUMPS Wastewater

### DIMENSIONS

(All dimensions are in inches. Do not use for construction purposes.)

#### Vertical Float Switch

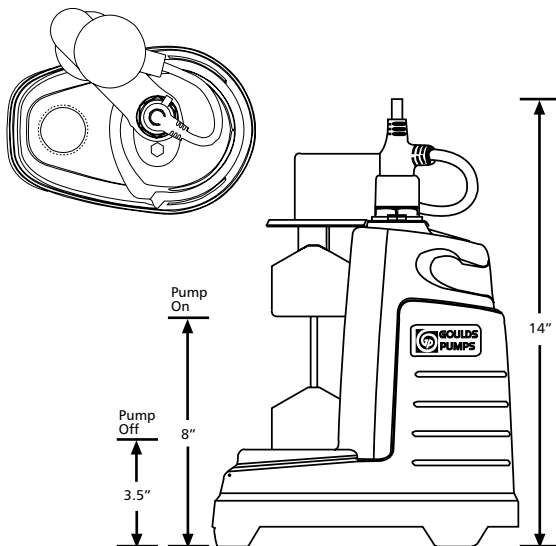

#### Wide Angle Float Switch

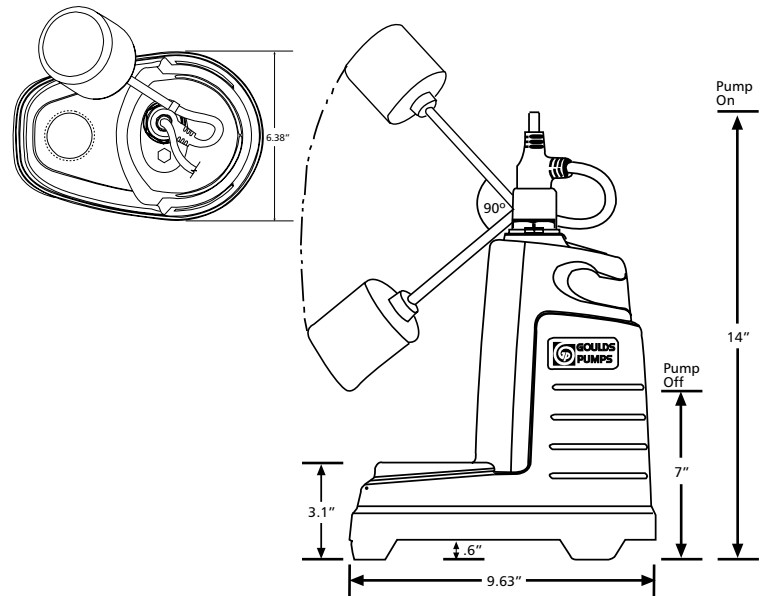

### PERFORMANCE RATINGS

#### ST31

Total Head (feet of water)	GPM	GPH
4	50	3,000
10	40	2,340
15	28	1,680
20	15	900

### MODEL INFORMATION

Order No.	HP	Volts	Amps	Minimum Circuit Breaker	Phase	Float Switch Style	Cord Length	Discharge Connection	Minimum On Level	Minimum Off Level	Minimum Basin Diameter	Maximum Solids Size	Shipping Weight lbs/kg
ST31AV	1/3	115	12.0	20	1	Built-In Vertical	10'	1 1/2"	8"	3.5"	11"	1/2	29 / 13.2
ST31A1						Built-In Wide Angle			14"	7"	18"		
ST31M						Plug / No Switch			Manual	Manual	11"		
ST31P1						Piggyback Wide Angle			14"	7"	18"		
ST31PV						Piggyback Vertical			8"	3.5"	11"		

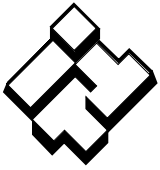

**ITT**

**Wastewater**



Goulds Pumps, SumpThing and the ITT Engineered Blocks Symbol are registered trademarks and tradenames of ITT Industries Inc.

SPECIFICATIONS ARE SUBJECT TO CHANGE WITHOUT NOTICE.

**BST31 March, 2006**

© 2006 ITT Water Technology, Inc.

*Engineered for life*